

*indigo*switch

---

Fan proving system



# Manual

**Model FPS2**

# Table of Contents

Application	2
Application limitations	3
Fan Proving and Emergency Shutoff Procedure	3
Air pressure and air flow proving	3
Auxiliary Switching	4
Fan proving and gas proving	4
Make up air proving	4
Action to be taken at the planning stage	5
Competency	5
Control Box Positioning and power supply	6
Thermostat Positioning	6
Air Pressure Switch Positioning	6
Venturi Positioning and Orientation	6
Electrical Installation	7
Commissioning Instructions	12
Cleaning and maintenance	13
Routine cleaning and safety checks	13
User Troubleshooting	14
Detailed Troubleshooting	15
Spare Parts List	16
Manufacturer & Warranty	16

## Application

**T**hank you for choosing the indigoswitch fan proving system. We developed this system after many years spent working with catering equipment installations, and it is this experience that led us to an understanding the problems with present-day pressure-switch based fan proving systems – and of how these problems could be solved.

Present day systems using a pressure switch to detect pressure differential between the extract duct and the kitchen have a problem, which is that air pressure switches are very sensitive to wind gusts, dirt ingress and turbulence. Also, the minimum sensitivity of such a switch is 0.2mBar, and this air pressure differential is only achieved when the airflow in the duct is relatively high. Paddle switches can only be successfully used in long, horizontal runs in relatively clean applications.

As the gas supply is mission critical, a highly reliable system is required. The indigoswitch system achieves this by having two routes to enable gas supply. It does this by monitoring three different attributes of the canopy and fan system:

1. The electrical current drawn by the extractor fan, as measured by a current switch.
2. The temperature adjacent to the bottom of the canopy.
3. The airflow inside the extractor system, as measured by a venturi fitted inside the extractor duct switching over an air pressure differential switch.

The indigoswitch will allow the gas to come on when the fan is switched on, and either the temperature next to the canopy is low enough or the airflow in the duct is high enough. To eliminate interference by wind gusts, turbulence, etc. an off-delay relay will allow the gas to stay on for a short period when the airflow is too low and the temperature is too high.

The gas safety regulations require that the extractor system is proven to remove all combustion products when all gas appliances are being used, yet the level of ventilation required at that point can be too high to allow a pleasant working environment when only very little gas is required. The indigoswitch system allows gas to be used safely in either of these circumstances by providing a switch point between the two.

In order to achieve this level of safety and functionality, the number of controls must inevitably be increased. This leads to a number of issues that must be considered at the kitchen planning stage. Liaison is required between the canopy installers, electrician and the gas installer and this should be done during the collaboration called for by BS6173-2001, paragraph 4.1. This is why the commissioning certificate included with the fan proving system has a section allowing the planning stages to be fully documented.

# Notes on System Limitations

## Application limitations

**Important!** The safety of the system indicated by the CE marking will become invalid if the installation instructions are not complied with!

The indigoswitch fan proving system is intended to switch an electric solenoid valve with a maximum rated input current of 1 A in commercial catering installations in the UK as required by BS6173: 2001 and IEC EN 60335-2-99: 2003. The normal environmental conditions to ensure safe operation are a permanently fixed installation which is:

- Indoor
- Ambient temperature 5 °C to 40 °C
- Maximum relative humidity 80 % for temperatures up to 31 °C decreasing linearly to 50% at 40 °C
- Mains supply voltage 240VAC  $\pm$  10%
- Pollution degree level 2
- The controlbox is not IP rated as the manufacturer has no control over the installation. To achieve IP rating, compliance must be verified after installation see electrical installation section for guidance.

## Fan Proving and Emergency Shutoff Procedure

In many gas installations, the gas solenoid valve supplying the catering equipment can also be used as an emergency shutoff valve. However, it is important to remember that this combined function is not always possible. For example, certain appliances do not rely on the mechanical extractor for safe operation, and their gas may be branched off the main supply before the solenoid. In this case, a suitably worded notice must be placed in the kitchen, showing what actions to take in an emergency, and clearly identifying the location and procedure for isolating the gas supply. Therefore, the knock-off switch fitted on the indigoswitch cannot automatically be used as an emergency isolator. However, in case there is another solenoid valve upstream of the interlock solenoid valve that is being used as emergency control, a spare gang is available on the knock off switch that can disconnect this upstream solenoid.

## Air pressure and air flow proving

Indigoswitch uses a simple venturi fitted inside the extractor duct. This will switch the air pressure differential switch over when there is a minimum of 5 meters per second air flow inside this duct. The advantage of this system is that it measures air flow as required by Health and Safety Executive in catering advice sheet No 23. If a system is used by simply using an air pressure difference between the inside and outside of the extract duct the gas supply may be left on in fault conditions such as blocked grease filters. The whole point of linking the gas supply to the extract system is to increase safety. Therefore the key factor that influences system performance, which is airflow, should be measured.

## Auxiliary Switching

Additional safety controls can be connected to the indigoswitch fan proving system, for example emergency stop knock off switches, CO detectors, fire alarm system links. These can be fitted in series instead of the link across the auxiliary terminals in the control box. Indigoswitch comes with a thermal fuse fitted to switch off the gas supply if the control box becomes too hot.

## Fan proving and gas proving

Indigoswitch fan proving system is not a gas proving system. Gas proving is necessary if there is any appliance beyond the solenoid valve that is not fully flame safety protected. A separate gas proving system can be installed, after indigoswitch and in series with it, provided that the total current requirement of both the gas solenoid and gas proving system does not exceed one ampere. If the gas proving system requires more current than this, an additional contactor is required.

## Make up air proving

Make up air is normally provided by permanent openings from the kitchen to the outside. Because indigoswitch proves the airflow in the canopy, the gas can be allowed to come on without separately proving the make up air fan.

If the make up air fan is not running, and all the doors and windows are closed, there may be insufficient make up air entering the kitchen to allow the extractor fan to maintain airflow to keep the air pressure switch beyond spillage point. In this case, the user may continue to use the gas system provided the canopy temperature remains below 30°C, and may open sufficient windows or doors to enable the extractor fan to operate correctly.

In some circumstances, a make-up air fan is necessary to avoid excessive drafts through serving hatches or to avoid smoke being drawn into the kitchen from adjoining rooms. In such cases, a separate air pressure switch and venturi system may be installed to operate a warning system (such as a light or buzzer) to notify catering personnel of system failure. If there is no gas safety issue, then linking the make-up air fan to the gas solenoid is not advisable.

# Installation Overview

## Action to be taken at the planning stage

- Check suitability of application
- Decide the position and orientation of the controlbox
- Decide number and position of thermostats
- Decide position and arrange accessibility of venturi(s)
- Decide position of Air Pressure Switch
- Decide number, position and orientation of gas solenoid(s) (note: gas solenoid is not included)
- Advise electrician about wiring diagram, controlbox power supply and installation instructions
- Keep documentary evidence of all planning decisions.

The indigoswitch system as delivered includes the following components:

- indigoswitch controller box
- this manual
- user operation sticker
- venturi
- air pressure switch
- thermostat
- PVC air tubing (2 metres)
- commissioning certificate.

Optional extras include:

- Knock off station
- Key start switch
- Norprene heat resistant air tube suitable for fitting inside canopy
- Buzzer
- Remote buzzer station
- Gas solenoid valve
- Heat resistant 3 core flex suitable for installing solenoid valves.

## Competency

A competent electrician must undertake all electrical work, according to the IEE wiring regulations (BS7671).

A CORGI registered installer, qualified for catering installations to BS6173, must commission the system.

## Control Box Positioning and power supply

Consider the following points when siting the indigoswitch control box:

- The power supply for the controlbox should be taken from the same isolator as the extractor fan supply. This is important as a separate isolator may lead service personnel to assume all conductors inside the controlbox are isolated whilst the fan supply may still be live. In case the fan speed controller has a facility to connect 240VAC equipment when the fan is on, this should be used. If there are live conductors inside the controlbox whilst the power supply is isolated (e.g. fire alarm links or other linked systems) a permanent, readily visible warning notice must be fitted adjacent to the controlbox power supply isolator, stating the correct isolating procedure.
- The most convenient place for the control box will normally be adjacent to the fan speed controller.
- If the knock off switch is to be used as an emergency control valve, then the box must be in a readily accessible position, preferably near the exit of the kitchen, site the controlbox high enough to avoid accidental operation of the knock off switch.
- The red alarm light must be visible to kitchen staff. Take this into account when positioning the box. Alternatively, remote warning lights or buzzers can be fitted.
- The ambient temperature of the control box should not exceed 40°C.

## Thermostat Positioning

The purpose of the thermostat is to detect spillage from the canopy. It should therefore be placed close to the lower canopy edge. In cases where spillage can occur at multiple points, or for large canopies, additional thermostats should be connected in series to monitor these points, as shown in the diagram "Optional Thermostats" on page 11.

## Air Pressure Switch Positioning

The air pressure switch is sensitive to vibration and requires access. Because of this, the ideal position is fixed vertically on a wall adjacent to the extract duct. The air tubes should run down to avoid the ingress of moisture or grease.

## Venturi Positioning and Orientation

The venturi should be fitted inside the extract duct in a position where it can be easily accessed for cleaning. Ideally, it should be placed between the terminal of the canopy and the first access door of the extract duct. If the placement means that there are access doors between the venturi and the canopy, a suitable worded notice must be affixed to these access doors, advising that they must be kept closed whenever gas appliances are in use. It is possible to site the venturi downstream of the fan, provided that there is no false air entering the duct between the kitchen and the fan as you need to measure the airflow taken from the kitchen.

The venturi is sensitive to turbulence, which is reduced over straight runs and increased at bends. For this reason, it is best to fit the venturi immediately in front of the extractor fan impeller or in a straight length of the extract duct away from any bends. Also, to avoid water ingress, the venturi should ideally be fitted in a horizontal duct section.

If the canopy has an internal fan that discharges directly to the outside, the venturi can be fitted in front of the impeller at the point of maximum airflow. A bracket and heat resistant air tube are available as optional extras.

Fix the venturi to the extract with the glands, preferably with the air tubes rising between venturi and air pressure switch to avoid ingress of dirt.

Note: for applications where there are more than one fans serving the same canopy, multiple venturis and air pressure switches must be fitted.

## Electrical Installation

The installation should be carried out according to IEE wiring regulations BS7671. To open the control box, undo the push-in and give each of the four securing screws a quarter turn. To facilitate preparing the enclosure base, remove the connector plate from the box by undoing the two securing screws.

The power supply for the controlbox should be taken from the same isolator as the extractor fan supply. This is important as a separate isolator may lead service personnel to assume all conductors inside the controlbox are isolated whilst the fan supply may still be live. In case the fan speed controller has a facility to connect 240VAC equipment when the fan is on, this should be used. If there are live conductors inside the controlbox whilst the power supply is isolated (e.g. fire alarm links or other linked systems) a permanent, readily visible warning notice must be fitted adjacent to the controlbox power supply isolator, stating the correct isolating procedure. The relay coils and LEDs inside the control box requires only a small amount of current, and most gas solenoid valves require less than 1A, so a 1A supply is sufficient to run both indigoswitch and the gas solenoid.

The fan supply loop monitors the current used by the extractor fan. The circuit will switch on when the fan draws more than 0.5A. With a three-phase fan, only one phase needs to be interrupted to go through the current switch. Internally, indigoswitch uses 1.5mm<sup>2</sup> wires to provide connection to the current switch. If this is insufficient, run a larger CSA wire through hole in the current switch, replacing the 1.5mm<sup>2</sup> black wire. The current switch threshold is 1A. In order to achieve a threshold of 0.5A, the fan conductor must be looped through the hole in the current switch twice. The current switch does not need the supply wire to the fan, it will also work when the Neutral wire is routed through the hole

The current switch closes when the fan supply conductor, routed through the hole, carries 1A (more properly, 0.5A, since the conductor is looped through the hole twice). The switch is sensitive to stray currents and may switch on without the fan being energised. You can adjust the sensitivity of the current switch by means of the small screw at the top of the device. The jumper stuck in the box next to the spare fuse may be used in case the sensitivity must be set to one of the higher ranges.

When connecting the thermostat(s) ensure that the wiring used can withstand the heat near the canopy. If the wiring can exceed 65 °C use high temperature cable.

Prepare the controlbox for suitable glands or conduit, the connections sub assembly can be easily removed by undoing the two securing screws and the cable tie. Connect all wiring as shown in the diagram "Indigoswitch External Connections" on page 10. When connecting extra thermostats in series, see the diagram "Optional Thermostats" on page 11 and connect the NC terminal of the first thermostat to the Com terminal of the next thermostat and the NC terminal of the last thermostat to the Thermostat NC terminal in the control box. The NO terminals of **all** thermostats must be connected to the Thermostat NO terminal in the control box

The link across the auxiliary switch terminals must be removed if additional remote switches are used (for example, CO detectors, remote knock-off buttons, or a link to a fire alarm). Please make a note on how to check any auxiliary systems in the user trouble shooting section of this manual

To increase system reliability, two gas solenoid valves may be used in parallel with a selector switch, ensure that the user is aware of how to switch between these valves and what to do in case one of them fails. Should the current required exceed 1A, then an extra contactor must be fitted.

To achieve an IP rating of 54 ensure that all glands used are suitably rated and seal any unused gland ports with a suitable sealant. If the knockout in the base of the controlbox is used seal the controlbox base to the wall using a suitable sealant. All the components and the enclosure are rated to IP54 or higher .

## Internal Wiring

1. Power On Indicator
2. Thermal Fuse
3. Current Switch
4. Remote Switch Proving Neon
5. Indicator Relay
6. Knock Off Switch
7. Red Lamp
8. Amber Lamp
9. Green Lamp
10. Off Delay Timer
11. Start Switch
12. EMC Filter

Colour Key  
 VI = Violet  
 BK = Black  
 GR = Green  
 BR = Brown  
 BL = Blue

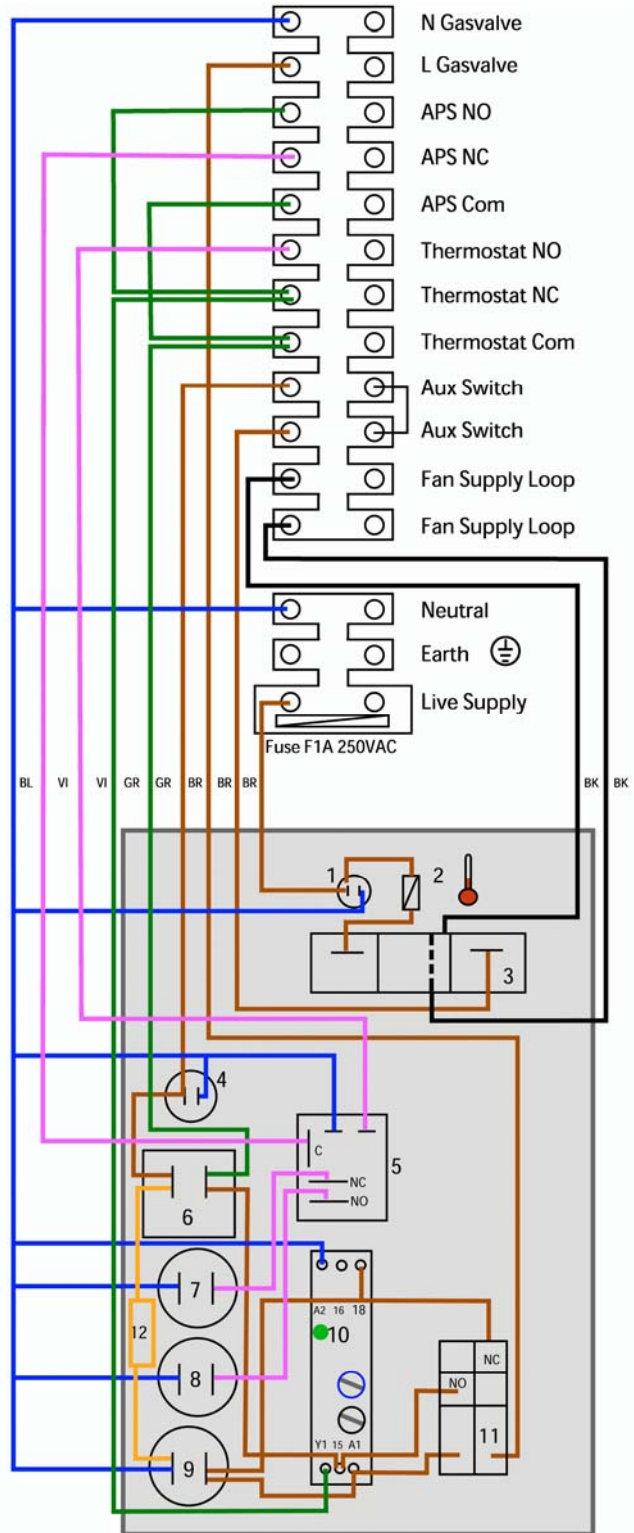

Figure 1 - Internal Wiring

## Indigoswitch External Connections

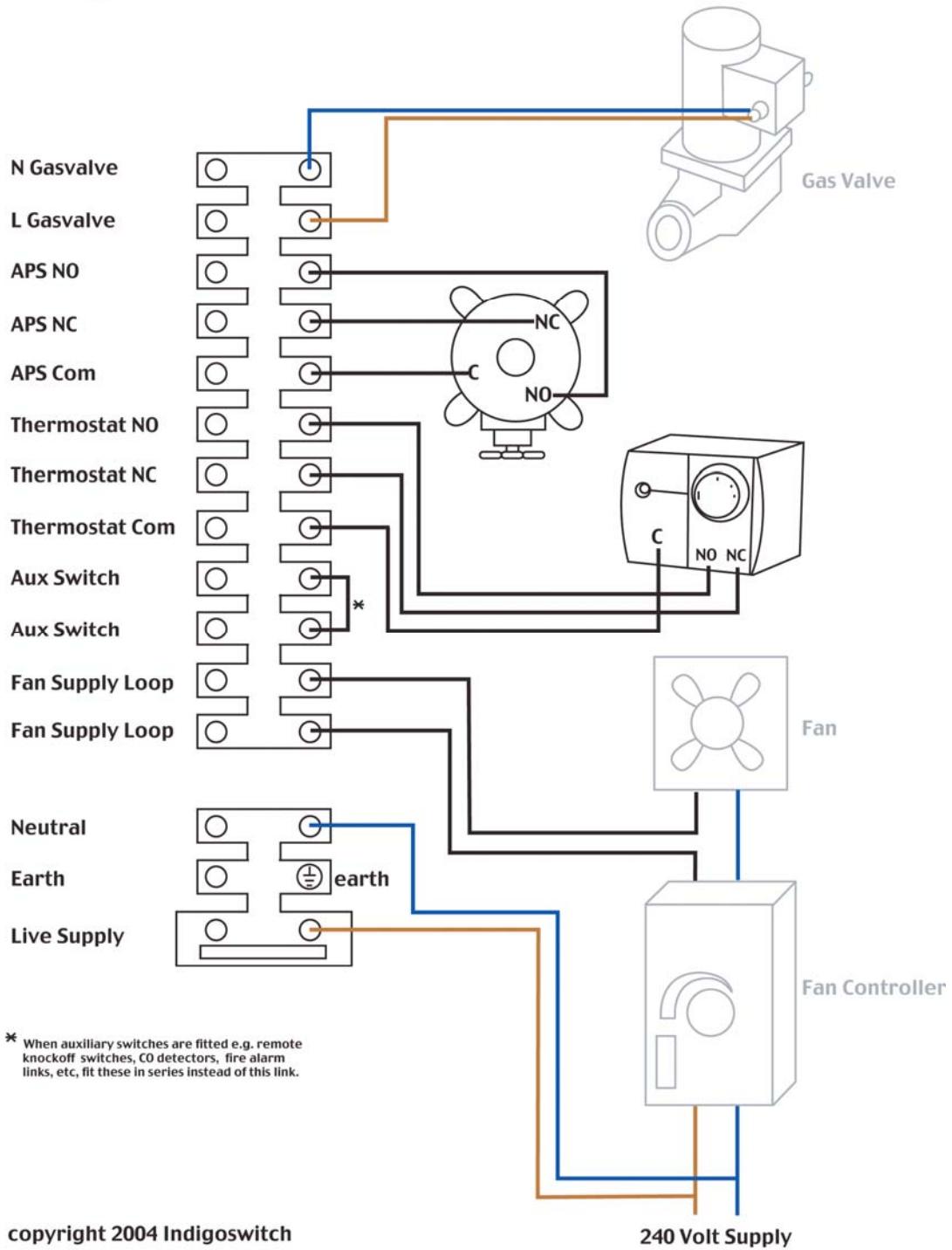

Figure 2 - Indigoswitch External Connections

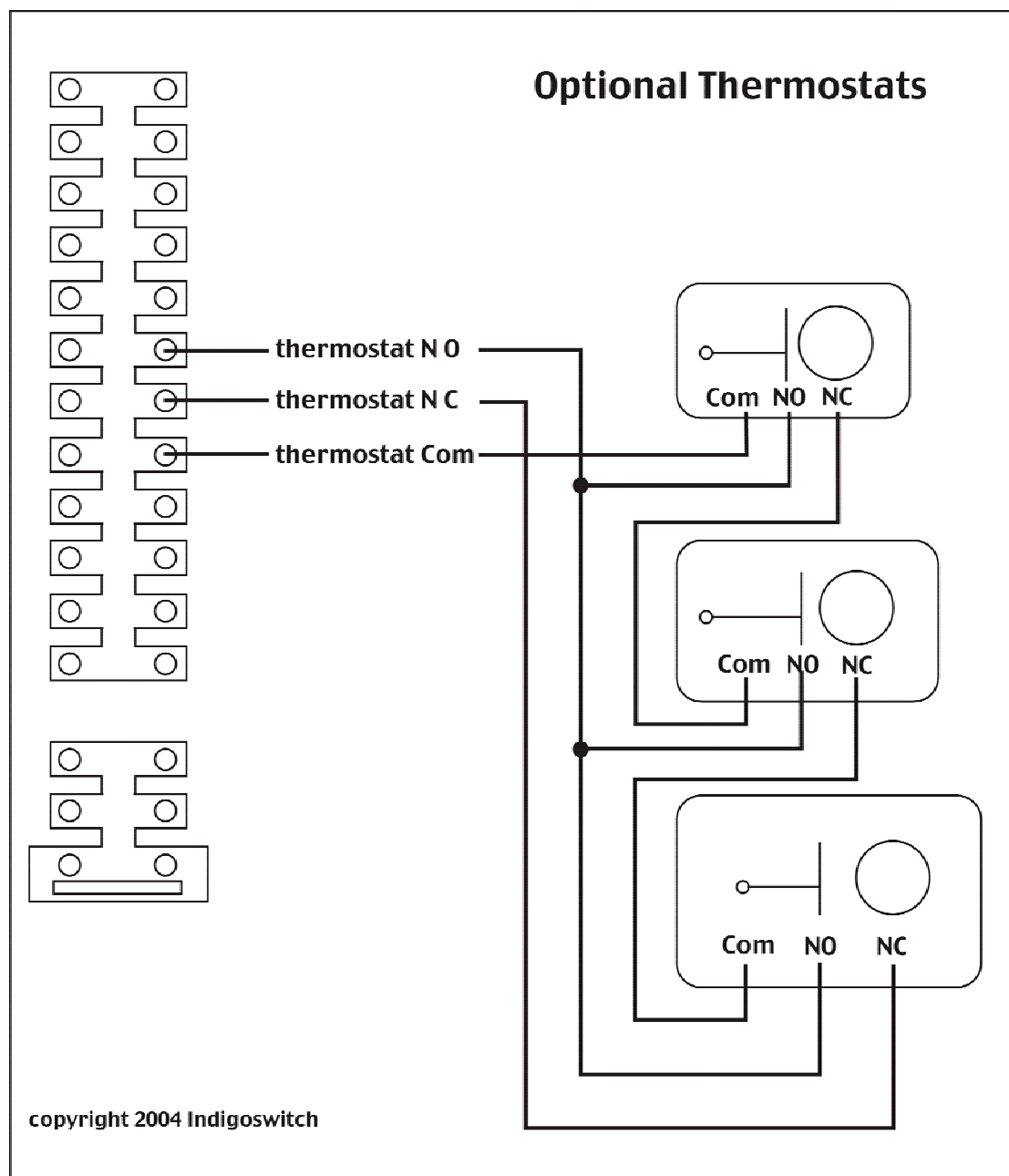

Figure 3 - Optional Multiple Thermostats

# Commissioning Instructions

In the event of problems, please see the Troubleshooting section on page 14.

## 1. Check Basic Operation

Disconnect the air tubes from the pressure switch and turn the extractor fan on. Ensure all remote links (such as knock-off switches) are calling for gas. The following lights should show:

- (Small red) Power On should be ON
- (Small green) Remote Switch Proven should be ON

Now press the start button.

- (Amber) Caution should be ON
- (Green) GAS ON should be ON.
- Whilst the start button is pressed the gas solenoid is de-energized.

## 2. Check Thermostat Operation

Turn the thermostat down below room temperature. The following lights should show:

- (Red) ALARM should be ON
- (Green) GAS ON should remain on, but should go off after approximately five minutes. As set by off delay relay.

Turn the thermostat back up to 30°C and press start button.

## 3. Check Air Pressure Switch Operation

Connect air tubes to the Air pressure Switch. Turn up the extractor fan to full. The following lights should show:

- (Amber) Caution should go off
- (Green) GAS ON should be on.

Turn off the fan.

- (Green) GAS ON should now be off.

The basic wiring is now correct.

## 4. Set up Thermostat Spillage Detection

Set the extractor fan running at minimum speed and ignite all gas appliances. This will cause hot combustion products to spill from under the canopy. Ensure that the thermostat switches over. If necessary, reduce the thermostat setting. Lock the thermostat in position with the breakaway temperature limiters.

## 5. Set up Venturi Switch Point

The air pressure switch should trip when the airflow drops below the spillage threshold.

- I. Ignite all gas appliances and reduce fan speed until combustion products start spilling.
- II. Mark the fan speed (this is the spillage point) and turn off all appliances.

- III. To avoid risk of electric shock, ensure that the live supply to the air pressure switch is turned off (the knock off switch can be used for this).
- IV. The air pressure switch, set at its lowest (0.2 mBar), will switch over when the airflow at the venturi is 4.5 metres per second. If the design of the extraction does not have airflow speed high enough, then extra fitting reducers must be fitted on the inlet side of the venturi to enable it to switch over sooner. Please phone our technical department for advice.
- V. Turn the switch point of the air pressure switch up so that it switches off with the fan running at the speed marked in step II. Check its operation several times by ensuring the APS switches off when the fan speed is reduced from high to spillage point. Finally repeat this test with the APS cover in place and all appliances on.

There are situations where the air pressure switch will not switch back on when fan is running at full speed when it is adjusted to switch off at spillage pint. The reason is that the difference between spillage point and maximum fan speed is not big enough. Please phone our technical department for advice

### **Hand over to User**

Demonstrate system operation and explain simple faultfinding as written on the operation sticker, which should be affixed near the control box in a readily visible position. Point out all remote auxiliary switching systems (if fitted) and write their details down in the user trouble shooting section. Explain that the system will work even when the kitchen gets hot, provided that the fan works at high speed.

Finally, hand over the completed commissioning certificate.

## Cleaning and maintenance

### Routine cleaning and safety checks

The control box and air pressure switch can be cleaned with a damp cloth and mild detergent. The thermostat can be wiped with a damp cloth provided there is no ingress of water into the thermostat housing. Routinely check the control box and components for damage and proper working order. Damaged components should be replaced by competent personnel. Do not open the control box unless you are competent. Routine operational checks: check that the airtubes and the venturi inside the ventilation duct are clean. This is an essential safety mechanism: ensure it is working correctly and take remedial action if it does not.

# Troubleshooting

## User Troubleshooting

If the green 'GAS ON' light does not come on at all when pressing the start button, proceed as follows:

- When red 'power on' indicator is not on: check power supply.
- When red power on indicator is on but green remote switch proven indicator is not on, then check remote knock-off buttons and other linked-in systems. The remote systems fitted are:

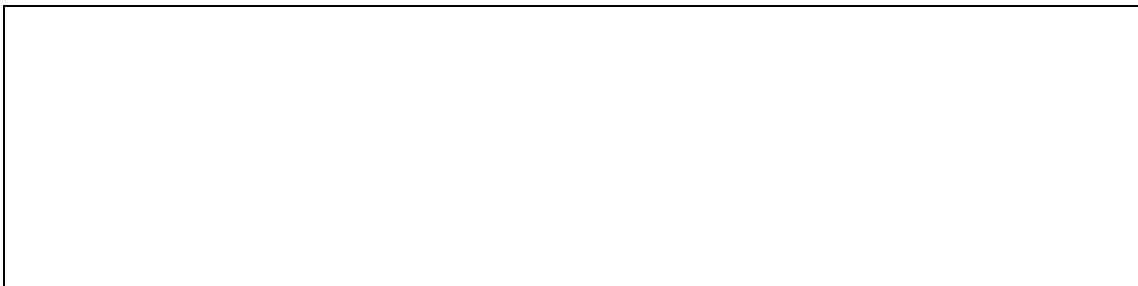

- When red light is on the gas has been switched off by the safety mechanism and the fan speed must be increased. Remember that when the red light is on, pressing the start button will not switch the gas on, the fan speed must be increased before the gas can come on.
- When green 'GAS ON' light is on but the gas is not check gas availability and solenoid valve. Remember that when the start button is pressed the gas valve is de-energised.
- When the green remote switch proven indicator is on but the green gas on lamp is off check whether the knock off switch needs resetting by turning it.
- When the amber light stays on even when the fan is running at full speed, the air pressure switch tubes are blocked and need to be cleaned. The gas will stay on provided the kitchen temperature does not exceed 28 C
- When the extractor fan is switched off, but the amber lights comes on, even momentarily, than the current switch is set too sensitive. Please get a qualified electrician to rectify this.

If this doesn't cure the problem, then a qualified technician must carry out more detailed faultfinding as follows.

## Detailed Troubleshooting

**Warning! Working on live electrical systems is dangerous and must only be carried out by competent technicians. Do NOT open the control box without isolating the supply.**

This section shows a trace through the indigoswitch components, starting with the positive power supply and following the brown wire through each component in turn. Refer also to the diagram "Indigoswitch Internal Connections" on page 9.

If the gas does not come on, check for 240V along the brown wire through the circuit (see the numbered component descriptions below) starting at the supply and ending with the gas valve.

### 1. Incoming Supply and 1A fuse

The incoming 240V supply is led through the 1A fuse. If the 1A fuse blows, do not increase the fuse amperage as the current switch requires protection.

### 2. Thermal fuse

If the fuse has blown, ensure that the cause of overheating is rectified. When safe, the fuse can be replaced by a link to enable gas supply while spares are organised.

### 3. Current Switch

This is connected across the 240V supply to the fan. If fan current falls too low, the current switch turns off disabling all subsequent components. If the fan is running and the current switch is not switching over, adjust the sensitivity by turning the adjusting screw on the top. If this doesn't cure the problem, then the current switch can be bypassed while spares are ordered. To do this, remove the brown wire from terminal T1 on the current switch, and join it into terminal L1 together with the thermal fuse. It is also necessary, in order to maintain a safe working environment, to remove the Thermostat NC terminal so that gas can only be used when the air pressure switch is calling for gas.

### 4. Off-delay Relay

Terminal 18 should have 240V provided terminal Y1 has 240V. To energise terminal Y1, the green wire should be traced starting at the knock-off switch, going out through either the thermostat or APS common and returning through thermostat NC and APS NO.

The start switch will energise terminal A1 through the NO contact block, whilst it will interrupt the gas valve supply through the NC contact block. The off-delay relay coil will only remain energized provided that terminal B1 has been energized as well. Terminal Y1 is energized by the green wire coming from the Thermostat NC or APS NO terminals. When the red light is on the gas valve will not be energized until the fan speed is increased.

If the relay fails, it can be bypassed while spares are ordered by taking the green wire from terminal Y1 and connecting it to terminal 18. This will by pass the time delay function as well as the start button function, so that the gas will go off immediately when the alarm light comes on. When bypassing this relay ensure that all personnel operating catering equipment are aware that the gas comes on automatically when the fan is switched on or when the APS or thermostat call for gas again. The right

operating sequence of ensuring that all appliance taps and pilots are turned off before the gas comes back on has now to be performed every time the gas goes off. Ensure that you make the catering staff aware of the importance of this safety check

The violet wires energise the red and amber warning lamps.

## Spare Parts List

Off delay relay

Current switch

Indicator relay

Red neon

Green neon

Green led lamp

Amber led lamp

Red led lamp

Knock off switch

Start switch

Temperature fuse assembly

Enclosure base

Enclosure lid

Capacitor assembly

## Manufacturer & Warranty

Indigoswitch™  
PO Box 49  
Cardigan  
SA43 3WZ  
0845 2263701

web site: [www.indigoswitch.co.uk](http://www.indigoswitch.co.uk)  
email: [info@indigoswitch.co.uk](mailto:info@indigoswitch.co.uk)

For queries and technical advice do not hesitate to contact us.

Due to our policy of continual improvement we reserve the right change components or appearance.

The Indigoswitch Fan proving system is covered by a twelve-month (from the date of purchase) return-to-base warranty against faulty components and workmanship, provided the installation instructions have been complied with. If a copy of the commissioning certificate has been returned to us the warranty will start on day of commissioning

**CE Compliance statement:**

This safety switch system does not comply with any of the harmonized safety standards required by law **unless all instructions mentioned in this manual have been complied with.** Manufacturer type testing, not to mention the entire customer expense of purchasing and installing, are meaningless without full compliance with all instructions in this manual.

In the event of fully documented compliance with the installation and user instructions this equipment complies with the following harmonised standard:

IEC EN 60370-1: 2001